

SWICHGAGE® Shutdown Panels for Mobile Equipment of All Kinds

WAI-94032B
Revised 08-03
Catalog Section 30
(00-02-0087)



WAI-7

WAI Series

- Get the Same Original Equipment Specified by Major OEM's
- SWICHGAGE® Instruments Include Built-in Light Pipe Illumination
- Prewired and Ready to Install
- Alarm Only Model Saves Money on Applications Not Requiring Shutdown
- Available for 12 or 24 Volts

Description

WAI Series Murphy panels offer engine protection for on and off road mobile equipment.

You get accurate engine readings and time-delayed automatic shutdowns. Flashing light and MINI-SIREN® signal a warning before the shutdown. Alarm-only panels (without shutdown capabilities) are also available.

WAI panels are easy to install and function test without the need for expensive auxiliary equipment. Each is a cost competitive and effective system for engine protection.

The WAI Series Panels are complete diagnostic, engine-protection systems. Any vehicle or engine can be monitored and in case of potentially damaging conditions an alarm will operate before the engine is shut down. WAI Panels feature direct-reading, mechanical SWICHGAGE® instruments (gauge and limit switch in one) and SELECTRONIC® relays and alarms. SWICHGAGE® instruments are internally lighted for night illumination.

Models Available

WAI-2: Completely enclosed and with convenient under-dash mounting provides SWICHGAGE® instruments for low oil pressure and high coolant temperature; visual and audible alarms before automatic shutdown. Includes a 270° pivoting, mounting bracket.

WAI-3: Same as WAI-2 panel with a 3rd SWICHGAGE® for block coolant pressure (0-15 psi).

WAI-4: Same as WAI-2 panel with a 3rd SWICHGAGE® for transmission temperature (140-300°F).

WAI-7: Open style panel same as WAI-2.

WAI-8: Open style panel provides SWICHGAGE® instruments for low oil pressure, coolant pressure and high coolant temperature; visual and audible alarms before automatic shutdown.

WAI-9: Open style panel same as WAI-8 with transmission temperature SWICHGAGE® instead of coolant pressure.

WAI-271: Open style panel similar to WAI-7 but for alarm-only.

Application

Trucks, buses, fork lifts, loaders, earth-movers—any engine powered mobile unit, such as delivery vans, farm and construction equipment, street sweepers.

Warranty

A limited warranty on materials and workmanship is given with this FW Murphy product. A copy of the warranty may be viewed or printed by going to www.fwmurphy.com/support/warranty.htm

MURPHY®

WAI-2



- Enclosed Panel
- Oil Pressure SWICHGAGE®
- Coolant Temperature* SWICHGAGE®
- MINI-SIREN®
- FL3/TL2 flasher and light
- 760AF Magnetic Switch with 30 second time delay for alarm before shutdown; 12 VDC, (optional 24 V)

WAI-3 / WAI-4



- Enclosed Panels
- Oil Pressure SWICHGAGE®
- Coolant Temperature* SWICHGAGE®
- Block Coolant Pressure* SWICHGAGE® (WAI-3 only 0-15psi)
- Transmission Temp.* SWICHGAGE® (WAI-4 only 140-300°F)
- MINI-SIREN®
- FL3/TL2 flasher and light
- 760AF Magnetic Switch with 30 second time delay for alarm before shutdown; 12 VDC, (optional 24 V)

WAI-7



- Open Style Panel
- Oil Pressure SWICHGAGE®
- Coolant Temperature* SWICHGAGE®
- MINI-SIREN®
- TL7, Flasher Alarm Light
- 760AF Magnetic Switch with 30 second time delay for alarm before shutdown; 12 VDC, (optional 24 V)

WAI-8 / WAI-9



- Open Style Panel
- Oil Pressure SWICHGAGE®
- Coolant Pressure* SWICHGAGE® (WAI-8 only 0-15psi)
- Transmission Temp.* SWICHGAGE® (WAI-9 only 140-300°F)
- Coolant Temperature* SWICHGAGE®
- MINI-SIREN®
- TL7, Flasher Alarm Light
- 760AF Magnetic Switch with 30 second time delay for alarm before shutdown; 12 VDC, (optional 24 V)

*Temperature capillary length is standard 6 ft. (1.8 m). Specify longer lengths.

- Alarm-Only, Open Style Panel
- Oil Pressure SWICHGAGE®
- Coolant Temperature* SWICHGAGE®
- MINI-SIREN®
- TL7, Flasher Alarm Light
- Available for 12 VDC or 24 VDC



*Temperature capillary length is standard 6 ft. (1.8 m). Specify longer lengths.

How to Order

**Order by using the model number
(also see the quick reference guide below):**

- WAI-2
- WAI-3
- WAI-4
- WAI-7
- WAI-8
- WAI-9
- WAI-271

STANDARD PANEL ASSEMBLIES AND KITS ~ QUICK REFERENCE GUIDE

Options like 24 VDC, special capillary length, delay time, etc, can be specified.

	WAI2	WAI3	WAI4	WAI7	WAI8	WAI9
Enclosed, easy-mount panel	✓	✓	✓			
Open, easy-mount panel				✓	✓	✓
201P-1-75 Engine oil pressure SWICHGAGE®	✓	✓	✓	✓	✓	✓
202T-1-220 Engine coolant temperature SWICHGAGE® (6 ft. [1.83 m] capillary)	✓	✓	✓	✓	✓	✓
202P-1-15 Engine coolant pressure SWICHGAGE®		✓			✓	
203T-1-300 Transmission temperature SWICHGAGE® (6 ft. [1.83 m]) warning-only			✓			✓
760AF SELECTRONIC® relay (30 second time delay, 12V)	✓	✓	✓	✓	✓	✓
TL7 SELECTRONIC® flashing alarm (12V, negative ground)				✓	✓	✓
TL2 and FL3 alarm light	✓	✓	✓			
SAH MINI-SIREN®	✓	✓	✓	✓	✓	✓
Diode 65010098, isolates transmission temperature for warning-only			✓			✓

Typical Dimensions

WAI-2

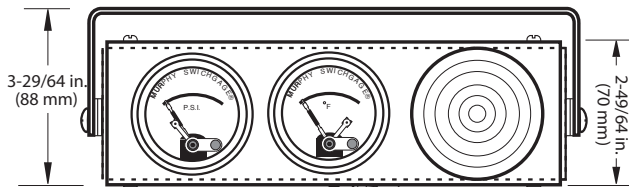
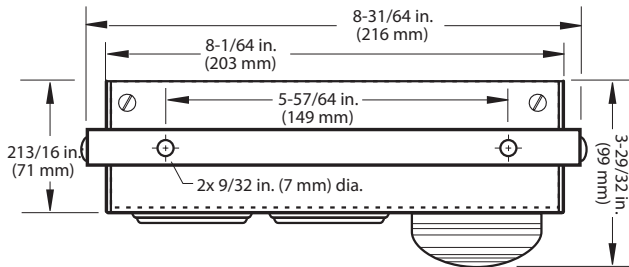

NOTE: Process Connection on pressure SWICHGAGE® is 1/8-27 NPT

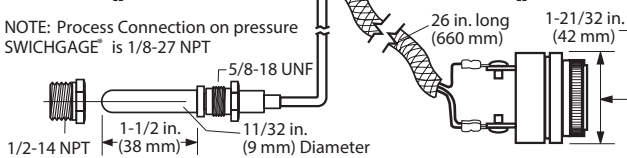

WAI-4 / WAI-4

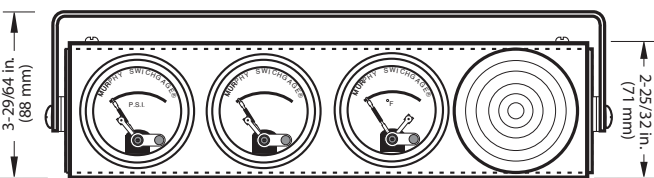
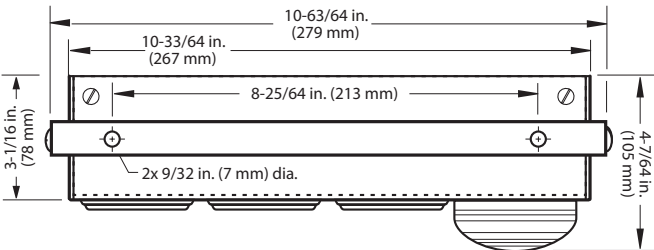

NOTE: Process Connection on pressure SWICHGAGE® is 1/8-27 NPT

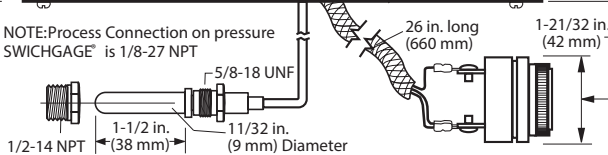

WAI-7

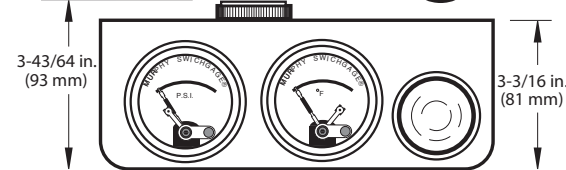
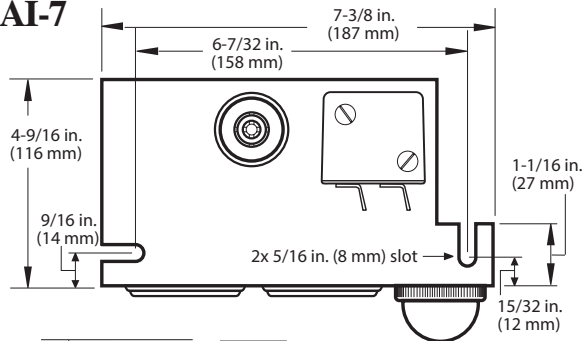

WAI-8 / WAI-9

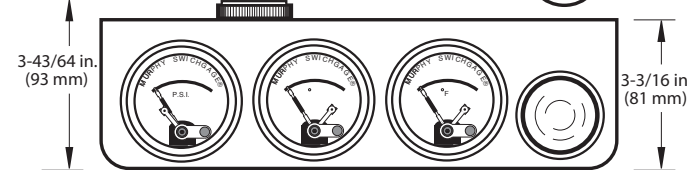
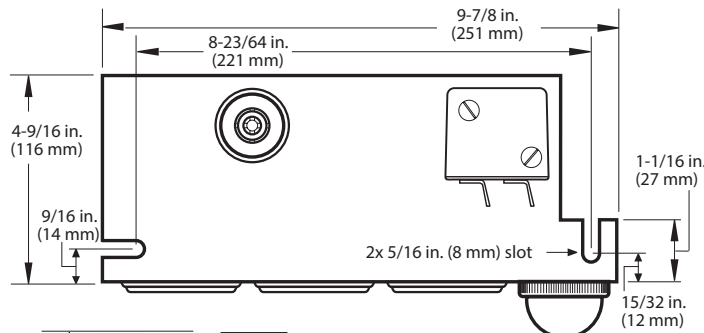

WAI-271

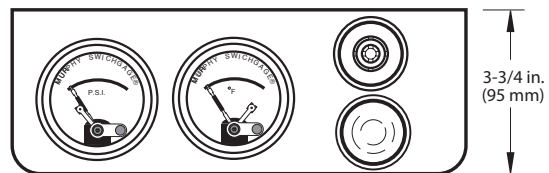
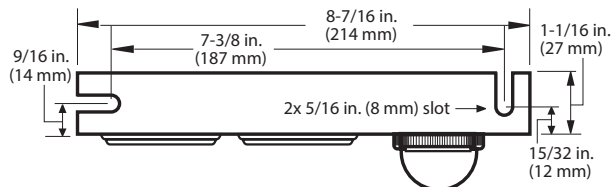

USA-ISO 9001:2009 FM 28221
UK-ISO 9001:2009 FM 29422